

Brass and stainless steel rotary vane pumps PO 500-1000 series

The high volume rotary vane pumps manufactured by Fluid-o-Tech® and sold worldwide under the trademark Rotoflow® are available in six flow ratings to meet the needs of high volume pumping.

Technical features and manufacturing characteristics

The rotary vane pump with brass or stainless steel body utilizes a stainless steel AISI 303 rotor, while the pumping chamber and the vanes are in carbon graphite. Inlet and outlet ports are 1/2" GAS or NPT threaded and the pump could be equipped with a built-in adjustable relief valve. The pump can be connected to coupling direct motor with a metallic clamp or to M71 and M80 UNELMEC frame motors with the Fluid-o-Tech® coupling and adapter set. Maximum operative temperature: 70 °C (158 F)

Available upon request:

- Viton® /EPDM seals
- Built-in relief valve
- Flange mount
- California AB 1953 compliant brass



MAIN APPLICATIONS

- Post mix drink dispensers
- Water treatment
- Cooling systems
- Booster systems



TECHNICAL INFORMATION

Pump housing material	Brass or stainless steel	Max static pressure	20 bar/290 psi
Pumping chamber	Carbon graphite	Pump weight	Clamp mount 1.9 kg (4.2 lb)
Ports	1/2" GAS or NPT		Flange mount 2 Kg (4.4 lb)
Speed limit	1725 rpm		

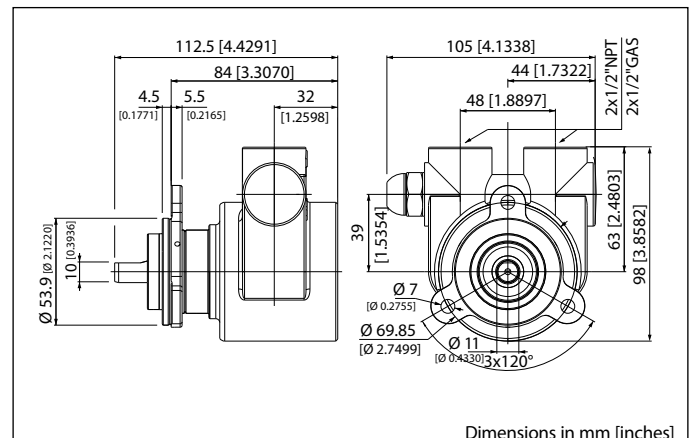
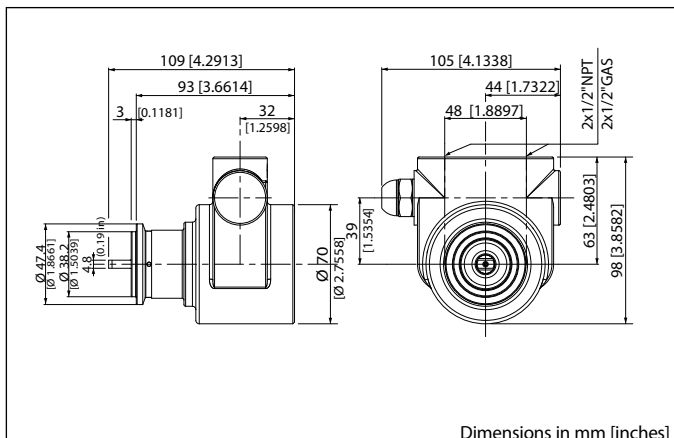

Brass and stainless steel rotary vane pumps PO 500-1000 series

Model PO/PA/PW Brass	500	501	500F	501F	600	601	600F	601F	700	701	700F	701F	800	801	800F	801F	900	901	900F	901F	1000	1001	1000F	1001F
Model PO/PA/PW Stainless Steel	510	511	510F	511F	610	611	610F	611F	710	711	710F	711F	810	811	810F	811F	910	911	910F	911F	1010	1011	1010F	1011F
Figure	L-L				M-M				N-N				P-P				R-R				S-S			
Relief valve	NO	YES	NO	YES	NO	YES	NO	YES	NO	YES	NO	YES	NO	YES	NO	YES	NO	YES	NO	YES	NO	YES	NO	YES
Flange mount	NO	NO	YES	YES	NO	NO	YES	YES	NO	NO	YES	YES	NO	NO	YES	YES	NO	NO	YES	YES	NO	NO	YES	YES
Clamp mount	YES	YES	NO	NO	YES	YES	NO	NO	YES	YES	NO	NO	YES	YES	NO	NO	YES	YES	NO	NO	YES	YES	NO	NO

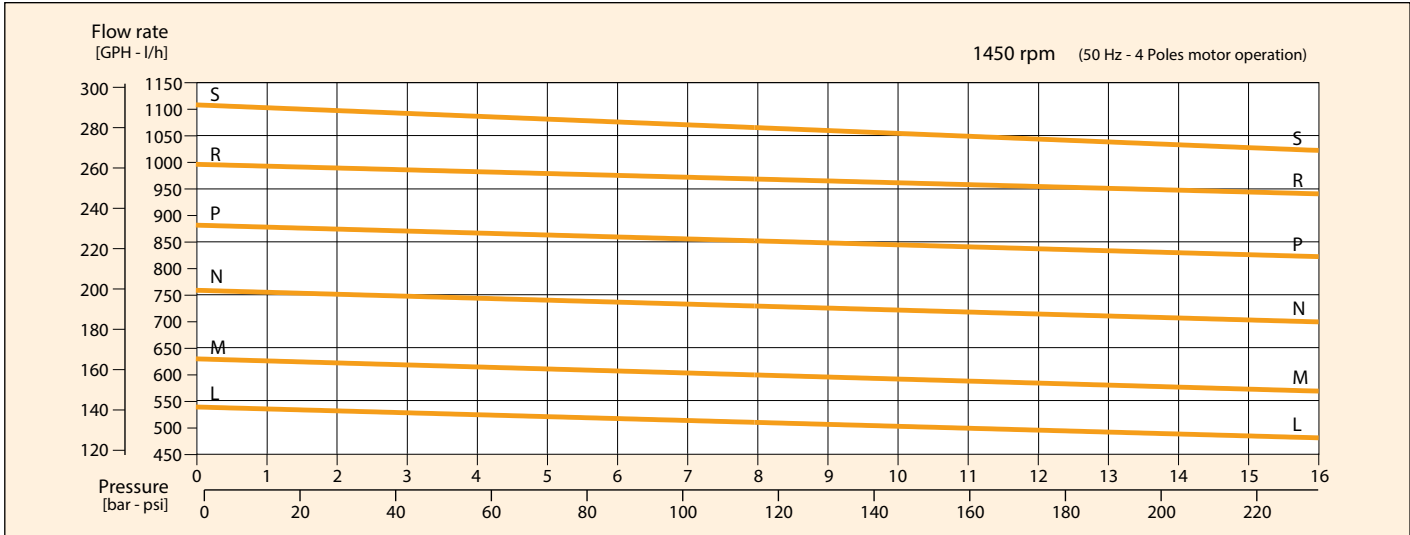

Model PO/PA/PW Brass	500	501	500F	501F	600	601	600F	601F	700	701	700F	701F	800	801	800F	801F	900	901	900F	901F	1000	1001	1000F	1001F
Model PO/PA/PW Stainless Steel	510	511	510F	511F	610	611	610F	611F	710	711	710F	711F	810	811	810F	811F	910	911	910F	911F	1010	1011	1010F	1011F
Figure	L'-L'				M'-M'				N'-N'				P'-P'				R'-R'				S'-S'			
Relief valve	NO	YES	NO	YES	NO	YES	NO	YES	NO	YES	NO	YES	NO	YES	NO	YES	NO	YES	NO	YES	NO	YES	NO	YES
Flange mount	NO	NO	YES	YES	NO	NO	YES	YES	NO	NO	YES	YES	NO	NO	YES	YES	NO	NO	YES	YES	NO	NO	YES	YES
Clamp mount	YES	YES	NO	NO	YES	YES	NO	NO	YES	YES	NO	NO	YES	YES	NO	NO	YES	YES	NO	NO	YES	YES	NO	NO

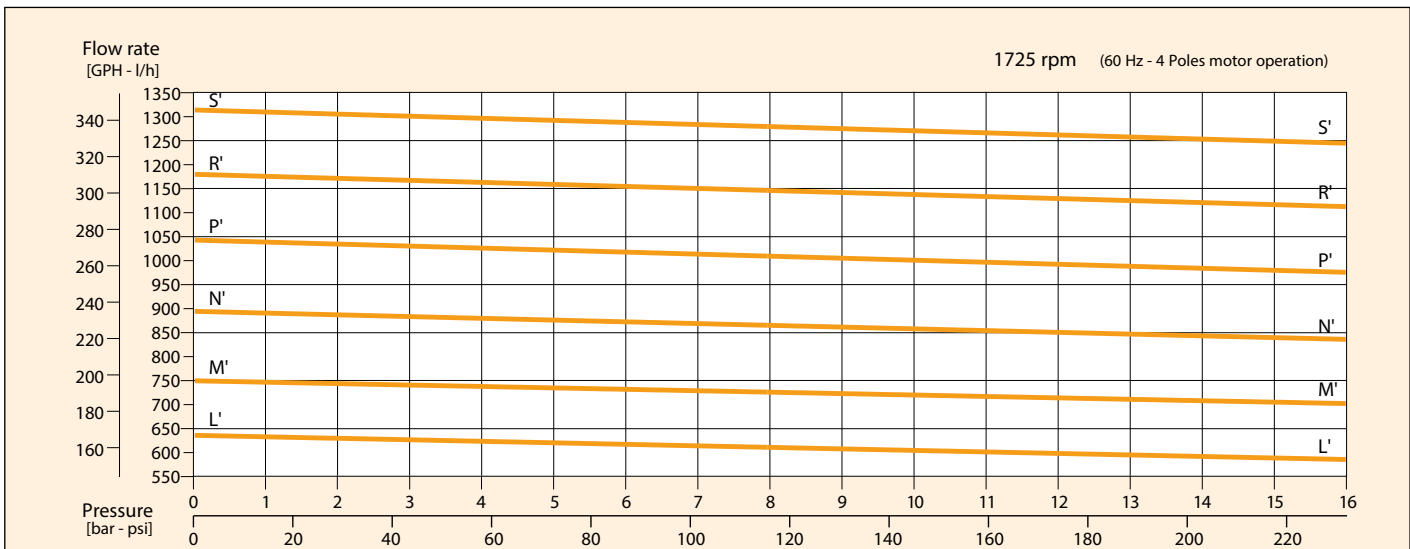

Note: Characteristics at constant motor speed, with water at 20 °C (68 F) and bypass blocked - Figures of flow are averages.
For applications involving other fluids, high temperatures or unusual processing conditions, please consult the factory or an authorized Fluid-o-Tech distributor.

Fluid-o-Tech reserves the right to alter the specifications indicated in this catalogue at any time and without prior notice.